

## SWING CHECK VALVE FLANGED END 150 LBS

Model : ARV-803FE(A)

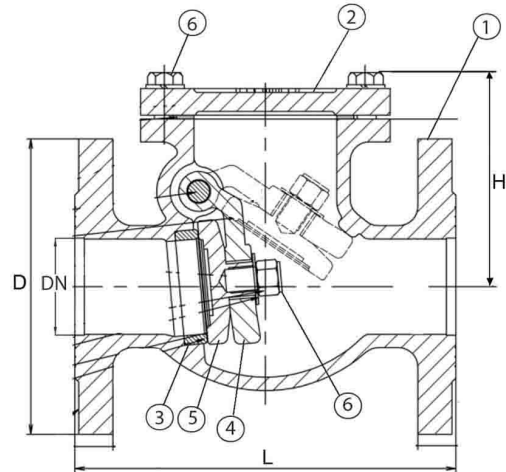

### Features :

- Face to face is according to ANSI B16.10
- Flange drilled is according to ANSI B16.1
- Working Pressure : 150 PSI
- Test Pressure Shell : 21.1 kgf/cm<sup>2</sup>
- Seat : 15.0 kgf/cm<sup>2</sup>
- Working Temperature : -10 to 120°C

## Technical Data

### Material

No	PART	MATERIAL
1	BODY	CAST IRON
2	BONNET	CAST IRON
3	DISC	CAST IRON
4	SEAT RING	CAST BRONZE / STAINLESS STEEL
5	INGE PEN	STAINLESS STEEL
6	DRAIN PLUG	CARBON STEEL

### Dimension in mm

SIZES	1.1/2"	2"	2.1/2"	3"	4"	5"	6"	8"	10"	12"
DN	40	50	65	80	100	125	150	200	250	300
L	180	203	220	240	292	330	356	495	622	698
H	101	105	115	140	155	170	203	246	283	330
D	127	152	178	191	229	254	279	343	406	483
Wt. (kg)	24	29	32.5	48.5	60	77	107	174	292	376