



UNIMECH GROUP, MALAYSIA



A MEMBER OF UNIMECH GROUP, MALAYSIA

## SWING CHECK VALVE FLANGED END 150 LBS

Model : ARV-803FE(A)

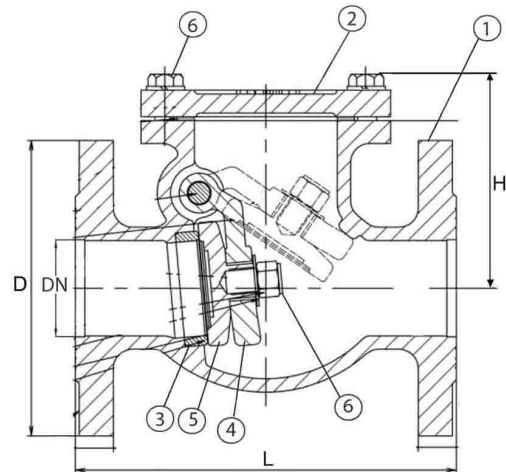

### Features :

- Face to face is according to ANSI B16.10
- Flange drilled is according to ANSI B16.1
- Working Pressure : 150 PSI
- Test Pressure Shell : 21.1 kgf/cm<sup>2</sup>
- Seat : 15.0 kgf/cm<sup>2</sup>
- Working Temperature : -10 to 120°C

## Technical Data

### Material

No	PART	MATERIAL
1	BODY	CAST IRON
2	BONNET	CAST IRON
3	DISC	CAST IRON
4	SEAT RING	STAINLESS STEEL
5	INGE PEN	STAINLESS STEEL
6	DRAIN PLUG	CARBON STEEL

### Dimension in mm

SIZES	1.1/2"	2"	2.1/2"	3"	4"	5"	6"	8"	10"	12"
DN	40	50	65	80	100	125	150	200	250	300
L	180	203	220	240	292	330	356	495	622	698
H	101	105	115	140	155	170	203	246	283	330
D	127	152	178	191	229	254	279	343	406	483
Wt. (kg)	24	29	32.5	48.5	60	77	107	174	292	376

The contents of this literature are for informative purposes only. Arita is not responsible for suitability or compatibility of these products in relation to system requirement. For specific requirements, consult Arita or its distributors. Arita reserves the right to change or modify product design without prior notice.