



UNIMECH GROUP, MALAYSIA



A MEMBER OF UNIMECH GROUP, MALAYSIA

## GATE VALVE FLANGED END 150LBS (NON RISING STEM)

Model : ARV-801FE(A)-NR

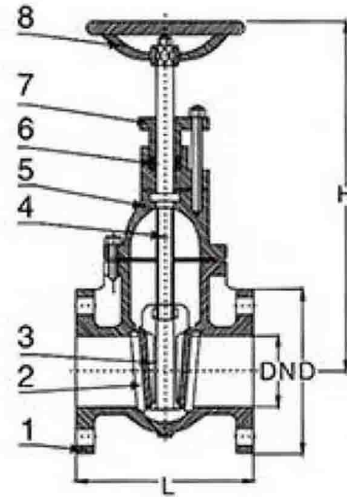

### Features :

Face to face is according to ANSI B16.10

Flange drilled is according to ANSI B16.1

Working Pressure : 150 PSI

Test Pressure Shell : 21.1 kgf/cm<sup>2</sup>

Seat : 15.0 kgf/cm<sup>2</sup>

Working Temperature : ≤200°C

### Technical Data

#### Material

| No | PART           | MATERIAL              |
|----|----------------|-----------------------|
| 1  | BODY           | CAST IRON (A126B)     |
| 2  | SEAT SEAL RING | STAINLESS STEEL       |
| 3  | DISC           | CAST IRON (A126B)     |
| 4  | STEM           | STAINLESS STEEL (410) |
| 5  | BONNET         | CAST IRON (A126B)     |
| 6  | PACKING        | GRAPHITE              |
| 7  | GLAND          | DUCTILE IRON          |
| 8  | HANDWHEEL      | CAST IRON (A126B)     |

### Dimension in mm

| SIZES    | 1.1/2" | 2"   | 2.1/2" | 3"  | 4"   | 5"  | 6"  | 8"  | 10" | 12" |
|----------|--------|------|--------|-----|------|-----|-----|-----|-----|-----|
| DN       | 40     | 50   | 65     | 80  | 100  | 125 | 150 | 200 | 250 | 300 |
| L        | 165    | 178  | 190    | 203 | 230  | 254 | 267 | 292 | 330 | 356 |
| H        | 245    | 255  | 275    | 295 | 370  | 425 | 460 | 580 | 695 | 785 |
| D        | 127    | 152  | 178    | 191 | 229  | 254 | 279 | 343 | 406 | 483 |
| Wt. (kg) | 26.5   | 27.5 | 32.5   | 43  | 61.5 | 82  | 109 | 176 | 278 | 362 |

The contents of this literature are for informative purposes only. Arita is not responsible for suitability or compatibility of these products in relation to system requirement. For specific requirements, consult Arita or its distributors. Arita reserves the right to change or modify product design without prior notice.

Our Ref. : ARG7- 09/24