



Cast Iron Marine Valves

TYPE DESIGNATION

MCI-SCV	JIS 5K SWING CHECK VALVES	JIS F7372
MCI-SCV	JIS 10K SWING CHECK VALVES	JIS F7373

Bolted Bonnet Renewable seat
Flanged Ends

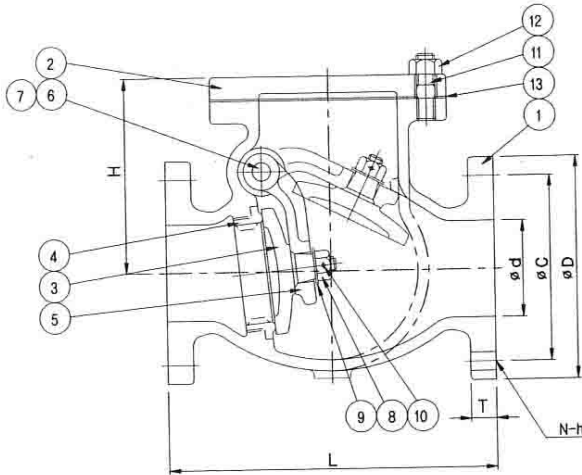

MATERIALS

NO.	PARTS	MATERIAL
1	BODY	CAST IRON
2	BONNET	CAST IRON
3	DISC	BRONZE/STAINLESS STEEL
4	BODY SEAT RING	BRONZE/STAINLESS STEEL
5	ARM	BRONZE
6	HINGE PIN	BRONZE
7	PLUG	BRONZE
8	DISC NUT	BRONZE
9	WASHER	BRASS
10	SPLIT PIN	BRASS
11	BONNET BOLT	STEEL
12	BONNET NUT	STEEL
13	GASKET	NON ASBESTOS

FLUID CONDITION & MAX.WORKING PRESSURE (kgf/cm²)

Fluid Condition	Rating	JIS 5K	JIS 10K
	Oil and Pulsation Water	5	5
Non-Shock Water up to 120 °C	7	7	14

TEST PRESSURE(kgf/cm²)

RATING	JIS 5K	JIS 10K
HYDROSTATIC PRESS TEST(SHELL)	10.5	21
HYDROSTATIC PRESS TEST(SEAT)	7.7	15.4

DIMENSIONS

Unit:mm

RATING	SIZE	50A	65A	80A	100A	125A	150A	200A	250A
JIS 5K (JIS F7372)	Ød	50	65	80	100	125	150	200	250
	ØD	130	155	180	200	235	265	320	385
	ØC	105	130	145	165	200	230	280	345
	N-Øh	4-15	4-15	4-19	8-19	8-19	8-19	8-23	12-23
	t	16	18	18	20	20	22	24	26
	L	190	220	250	280	330	380	460	550
	H	97	119	129	146	171	198	235	290
Weight(Kg)		9.06	13.9	19.1	27.1	39.0	53.7	94.4	150
JIS 10K (JIS F7373)	Ød	50	65	80	100	125	150	200	
	ØD	155	175	185	210	250	280	330	
	ØC	120	140	150	175	210	240	290	
	N-Øh	4-19	4-19	8-19	8-19	8-23	8-23	12-23	
	t	20	22	22	24	24	26	26	
	L	210	240	270	300	350	400	480	
	H	109	126	136	153	180	205	242	
Weight(Kg)		13.6	19.6	22.6	30.9	49.2	64.9	103	

REMARK: 1. The flanges shall conform to nominal pressure 5K and 10K of JIS B 2210

