

Cast Iron Marine Valves

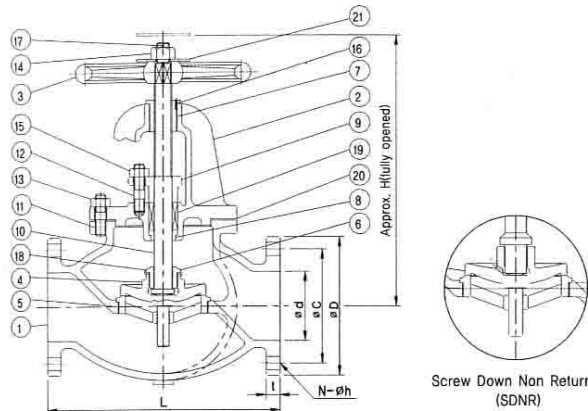

TYPE DESIGNATION

MCI-SDV	JIS 5K GLOBE SCREW-DOWN CHECK VALVES	JIS F7353
MCI-SDV	JIS 10K GLOBE SCREW-DOWN CHECK VALVES	JIS F7375
MCI-SDV	JIS 16K GLOBE SCREW-DOWN CHECK VALVES	JIS F7377



Bolted Bonnet Renewable seat
Rising Stem Flanged Ends

MATERIALS

NO.	PARTS	MATERIAL
1	BODY	CAST IRON
2	BONNET	CAST IRON
3	HANDWHEEL	CAST IRON
4	DISC	BRONZE/STAINLESS STEEL
5	VALVE SEAT	BRONZE/STAINLESS STEEL
6	DISCS NUT	BRONZE/STAINLESS STEEL
7	SCREW BONNET BUSH	BRONZE/STAINLESS STEEL
8	BONNET BUSH	BRONZE/STAINLESS STEEL
9	PACKING GLAND	BRONZE
10	STEM	BRONZE/STAINLESS STEEL
11	STUD BOLT	STEEL
12	STUD BOLT	STEEL
13	HEXAGON NUT	STEEL
14	HEXAGON NUT	STEEL
15	HEXAGON NUT	STEEL
16	LOCK PIN	STEEL
17	SPLIT PIN	BRASS
18	DISC LOCK WASHER	BRASS
19	PACKING	NON ASBESTOS
20	GASKET	NON ASBESTOS
21	WASHER	STEEL

FLUID CONDITION & MAX.WORKING PRESSURE (kgf/cm²)

Rating	Max.Working Pressure(kgf/cm ²)									
	JIS 5K		JIS 10K				JIS 16K			
	Up to 200A	250A to 400A	Up to 200A	Over 250A	50A to 200A					
Fluid Condition	Class B	Class S	Class B	Class B	Class S	Class B	Class S	Class B	Class S	
Steam up to 230°C	-	5	-	-	10	-	-	-	16	16
Steam up to 205°C	5	5	-	-	10	-	-	-	16	16
Saturated Steam			10				5			
Air and Gas	5(Up to 300A)						16			
Oil and Pulsation water	5						10			
Non-Shock Water up to 120°C	7(Up to 300A)	6	14				22			

TEST PRESSURE(kgf/cm²)

RATING	JIS 5K		JIS 10K		JIS 16K
SIZE	Up to 300A	350A to 400A	Up to 200A	Over 250A	50A to 200A
Globe/Globe Check(SDNR)					
HYDROSTATIC PRESS TEST(SHELL)	10.5	9	21	15	33
HYDROSTATIC PRESS TEST(SEAT)	7.7	6.6	15.4	11	24.2

DIMENSIONS

RATING	SIZE	50A	65A	80A	100A	125A	150A	200A	250A	300A	350A	400A	Unit:mm	
JIS 5K (JIS F7353)	Ød	50	65	80	100	125	150	200	250	300	335	380		
	ØD	130	155	180	200	235	265	320	385	430	480	540		
	ØC	105	130	145	165	200	230	280	345	390	435	495		
	N-Øh	4-15	4-15	4-19	8-19	8-19	8-19	8-23	12-23	12-23	12-23	12-25	16-25	
	t	16	18	18	20	20	22	24	26	28	30	30		
	L	210	250	280	340	410	480	570	740	840	940	1050		
	H	270	300	310	56.9	390	445	530	650	740	840	940		
Weight(Kg)	14.7	21.3	27.7	40.8	57.6	80.3	139	246	377	462	647			
JIS 10K (JIS F7375)	Ød	50	65	80	100	125	150	200	250	300				
	ØD	155	175	185	210	250	280	330	400	445				
	ØC	120	140	150	175	210	240	290	355	400				
	N-Øh	4-19	4-19	8-19	8-19	8-23	8-23	12-23	12-25	16-25				
	t	20	22	22	24	24	26	26	30	32				
	L	220	270	300	350	420	490	570	740	840				
	H	285	310	320	370	420	470	555	680	770				
Weight(Kg)	19.9	28.7	32.4	48.7	73.1	104	162	304	458					
JIS 16K (JIS F7377)	Ød	50	65	80	100	125	150	200						
	ØD	155	175	200	225	270	305	350						
	ØC	120	140	160	185	225	260	305						
	N-Øh	8-19	8-19	8-23	8-23	8-25	12-25	12-25						
	t	20	22	24	26	26	28	30						
	L	220	270	300	350	430	500	570						
	H	285	310	340	385	455	510	630						
Weight(Kg)	19.6	28.3	40.4	56.9	89.5	123	188							

REMARK: 1. The flanges shall conform to nominal pressure 5K, 10K and 16K of JIS B 2210
2. The name plate shall be specified by purchaser as required



reserves the right to make changes in design, materials or specifications without prior notice and free of obligation to furnish or install such changes on products previously sold.