

Cast Bronze Marine Valves

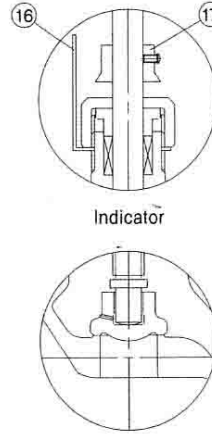

TYPE DESIGNATION

MBC-SDV	JIS 5K GLOBE SCREW-DOWN CHECK VALVES	JIS F7351
MBC-SDV	JIS 10K / 16K GLOBE SCREW-DOWN CHECK VALVES	JIS F7409(10)/JIS F7409

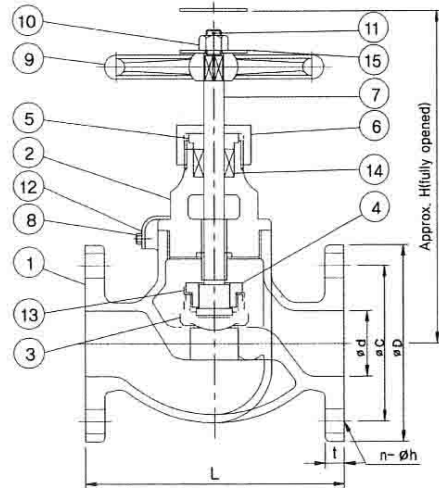

Screw Down Non Return (SDNR)

Screwed Bonnet Integral seat
Rising Stem Flanged Ends

FLUID CONDITION & MAX.WORKING PRESSURE (kgf/cm²)

Fluid Condition	Rating	JIS 5K	JIS 10K	JIS 16K
		Steam up to 205 C	4.9	10
Air, Gas, Oil and Pulsation water				
Non-Shock Water up to 120 C		6.9	14	33

TEST PRESSURE (kgf/cm²)

RATING	JIS 5K	JIS 10K	JIS 16K
HYDROSTATIC PRESS TEST(SHELL)	10.3	21	33
HYDROSTATIC PRESS TEST(SEAT)	7.6	15.5	24.2

MATERIALS

NO.	PARTS	MATERIAL
1	BODY	BRONZE
2	BONNET	BRONZE/BRASS
3	DISC	BRONZE/BRASS
4	VALVE DISC NUT	BRASS
5	PACKING GLAND	BRASS
6	GLAND NUT	BRASS
7	STEM	BRASS
8	SET SCREW	BRASS
9	HANDWHEEL	CAST IRON
10	HEXAGON NUT	BRASS
11	SPLIT PIN	BRASS
12	LOCK PLATE	BRASS
13	DISC LOCK WASHER	BRASS
14	PACKING	NON ASBESTOS
15	WASHER	STEEL
16	INDICATOR PLATE	BRASS
17	INDICATOR PIECE	BRASS

DIMENSIONS

Unit:mm

RATING	SIZE	Ød	ØD	ØC	N-Øh	t	L	H	weight(kg)
JIS 5K (JIS F7351)	15A	15	80	60	4-12	9	100	130	2.02
	20A	20	85	65	4-12	10	110	140	2.86
	25A	25	95	75	4-12	10	120	160	3.54
	32A	32	115	90	4-15	12	140	170	5
	40A	40	120	95	4-15	12	160	190	6.48
	50A	50	130	105	4-15	14	210	235	11.7
	65A	65	155	130	4-15	14	250	260	17
JIS 10K / JIS 16K (JIS F7409(10)/JIS F7409)	15A	15	95	70	4-15	12	110	130	2.76
	20A	20	100	75	4-15	14	120	140	3.72
	25A	25	125	90	4-19	14	130	160	5.2
	32A	32	135	100	4-19	16	160	170	6.91
	40A	40	140	105	4-19	16	180	190	8.43

REMARK: 1.The flanges shall conform to nominal pressure 5K,10K and 16K of JIS B 2240
2.JIS F7301 5K for nominal dia 50 and 65 shall be made Bolted Bonnet type



reserves the right to make changes in design, materials or specifications without prior notice and free of obligation to furnish or install such changes on products previously sold.