

TYPE DESIGNATION

MBC-BV2

CAST BRONZE 2-WAY BALL VALVE

JIS 5K / JIS 10K / JIS 16K

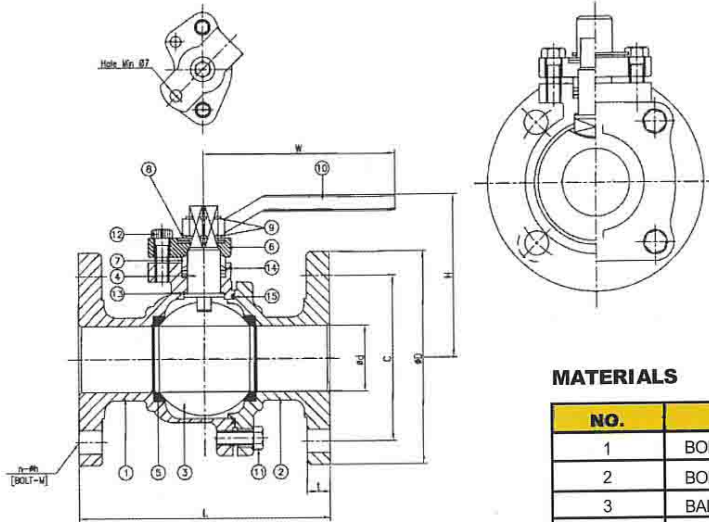

VALVE SPECIFICATION SHEET

RATING		JIS 5K	JIS 10K	JIS 16K
STANDARD'S	FACE TO FACE	JIS B2002		
	FLANGE DIMENSION	JIS B2210		
	BASIC DESIGN	JIS B2081		
	INSPECTION & TESTING	JIS B2003		
HYDROSTATIC TEST PRESSURE	BODY	12 kgf / cm ²	24 kgf / cm ²	38 kgf / cm ²
	SEAT	8 kgf / cm ²	15 kgf / cm ²	24 kgf / cm ²

MATERIALS

NO.	PARTS	MATERIAL
1	BODY	BC 6
2	BODY CAP	BC 6
3	BALL	SUS 304
4	STEM	C 3604
5	SEAT RING	PTFE
6	GLAND FLANGE	BC 6
7	GLAND RING	C 3604
8	STOPPER	SS 400
9	STOP RING	SUS 304
10	LEVER HANDLE	AL
11	HEX BOLT	SUS 304
12	GLAND BOLT	SUS 304
13	THRUST WASHER	PTFE
14	GLAND PACKING	PTFE
15	GASKET	PTFE

DIMENSIONS

Unit:mm

RATING	SIZE	Ød	C	ØD	H	L	W	t	N-Øh
JIS 5K	15A	15	70	95	105	110	123	12	4-15
	20A	20	75	100	107	120	123	14	4-15
	25A	25	90	125	117	130	143	14	4-19
	32A	32	100	135	122	160	143	16	4-19
	40A	40	105	140	130	180	233	16	4-19
	50A	50	120	155	135	178	233	16	8-19
	65A	65	140	175	155	190	270	18	8-19
	80A	80	160	200	172	203	270	20	8-23
100A	100	185	225	214	229	400	22	8-23	
JIS 10K	15A	15	70	95	105	110	123	12	4-15
	20A	20	75	100	107	120	123	14	4-15
	25A	25	90	125	117	130	143	14	4-19
	32A	32	100	135	122	160	143	16	4-19
	40A	40	105	140	130	180	233	16	4-19
	50A	50	120	155	135	178	233	16	4-19
	65A	65	140	175	155	190	270	18	4-19
	80A	80	160	185	172	203	270	18	8-19
100A	100	175	210	214	229	400	18	8-19	
JIS 16K	15A	15	70	95	105	110	123	12	4-15
	20A	20	75	100	107	120	123	14	4-15
	25A	25	90	125	117	130	143	14	4-19
	32A	32	100	135	122	160	143	16	4-19
	40A	40	105	140	130	180	233	16	4-19
	50A	50	120	155	135	178	233	16	8-19
	65A	65	140	175	155	190	270	18	8-19
	80A	80	160	200	172	203	270	20	8-23
100A	100	185	225	214	229	400	22	8-23	

REMARK: 1.The flanges connection will be adjusted by purchaser's requirement
2.The name plate shall be specified by purchaser as required