



UNIMECH GROUP, MALAYSIA



A MEMBER OF UNIMECH GROUP, MALAYSIA

Y-STRAINER SCREWED END

Model : ARV-1005SE



DN15-DN65
14 mesh per inch

Screen Dimension

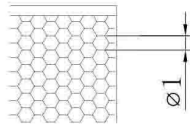

DN80-DN100
16 mesh per inch

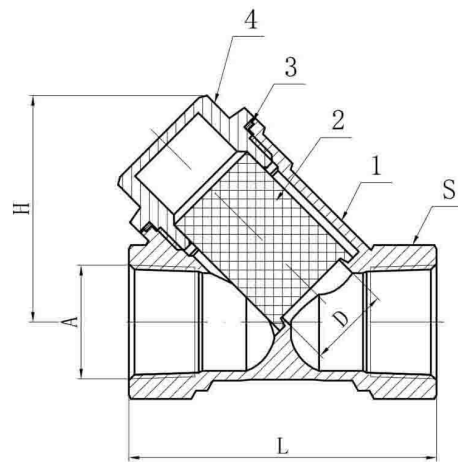

Technical Data

Specification

Nominal Pressure	PN ≤ 1.6 Mpa
Shell Test Pressure	2.4 Mpa
Applicable Temperature	-20~ 110°C
Applicable Media	water, non-corrosive liquid
Screwed End	BSPT

Material

No	PART	MATERIAL
1	BODY	BRASS
2	FILTER	SS 304
3	SEALING GASKET	TEFLON
4	BONNET	BRASS

Dimension in mm

Size		D	L	H	S	Weight (kg)
DN	A					
15	Rc1/2"	14.5	55	41	26	0.155
20	Rc3/4"	20	68	47	32	0.235
25	Rc1"	24	80	60	39	0.37
32	Rc1.1/4"	30	90	68	48.5	0.56
40	Rc1.1/2"	35	101	77	54	0.72
50	Rc2"	48	125	93	67	1.25
65	Rc2.1/2"	64	176	121	84	2.5
80	Rc3"	70	188	129	97	3.48
100	Rc4"	85	180	150	123	5.8

The contents of this literature are for informative purposes only. Arita is not responsible for suitability or compatibility of these products in relation to system requirement. For specific requirements, consult Arita or its distributors. Arita reserves the right to change or modify product design without prior notice.

Our Ref. : ARBYAS- 09/23