

KNIFE GATE VALVE FLANGED END 150LBS (LUG TYPE)

Model : ARV-110FE(A)

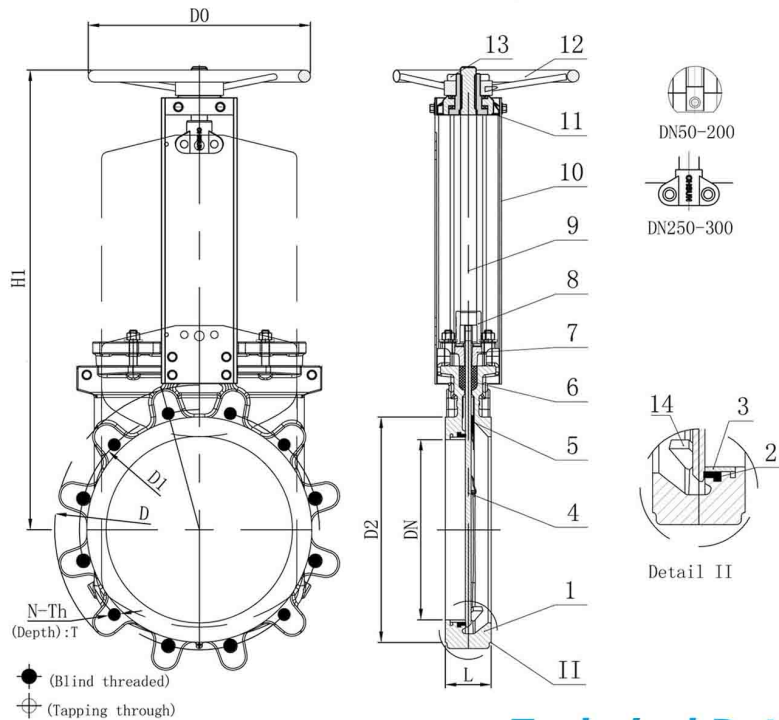

Features :

- Working Pressure : 10 bar / 150 psi
- Working Temperature : -10 to 120°C
- Flange Connection : ANSI B16.5 (Class 150)

Material

No	PART	MATERIAL
1	BODY	CF8 / CF8M
2	SEAT	EPDM + PTFE
3	STEEL RING	SS304 / SS316
4	DISC	SS304 / SS316
5	GUIDE PAD	PTFE
6	PACKING	PTFE
7	PACKING GLAND	WCB / CF8

Technical Data

No	PART	MATERIAL
8	CHUCK	WCB
9	STEM	SS304
10	YOKE	Q235 (Cr.D)
11	YOKE HEAD	Assembly
12	HANDWHEEL	CAST IRON (GGG40)
13	CAP	Q235 (Cr.D)
14	WEDGE	CF8 / CF8M

Dimension in mm

DN	L	D	D1	D2	D0	N-Th	T	●	⊕	d	H1
50	48	152	121	92	180	4-M5/8-11	12	4	0	Ø19	292
65	48	178	140	105	200	4-M5/8-11	12	4	0	Ø19	320
80	51	191	153	127	200	4-M5/8-11	12	8	0	Ø19	348
100	51	229	191	157	240	8-M5/8-11	12	8	0	Ø19	395
125	57	254	216	186	260	8-M3/4-10	14	8	0	Ø22	450
150	57	279	242	216	280	8-M3/4-10	14	8	0	Ø22	504
200	70	343	299	270	300	8-M3/4-10	18	8	0	Ø22	617
250	70	400	362	324	320	12-M7/8-9	18	12	0	Ø25	758
300	76	483	432	381	350	12-M7/8-9	20	12	0	Ø25	857

The contents of this literature are for informative purposes only. Arita is not responsible for suitability or compatibility of these products in relation to system requirement. For specific requirements, consult Arita or its distributors. Arita reserves the right to change or modify product design without prior notice.