

## KNIFE GATE VALVE FLANGED END JIS 10K (LUG TYPE)

Model : ARV-110FE(J)

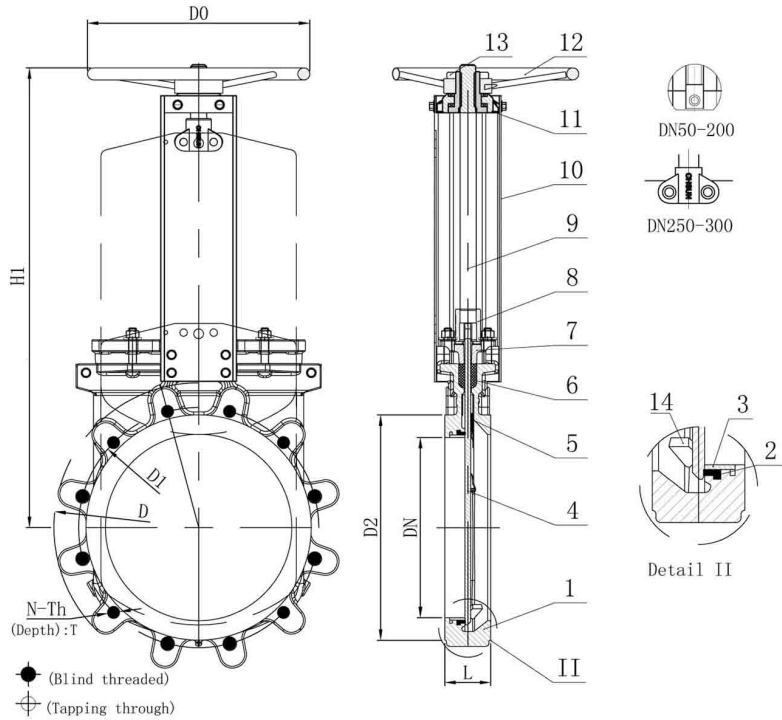

### Features :

- Working Pressure : 10 bar / 150 psi
- Working Temperature : -10 to 120°C
- Flange Connection : JIS 10K
- JIS B2220-2012

## Technical Data

### Material

No	PART	MATERIAL
1	BODY	CF8 / CF8M
2	SEAT	EPDM + PTFE
3	STEEL RING	SS304 / SS316
4	DISC	SS304 / SS316
5	GUIDE PAD	PTFE
6	PACKING	PTFE
7	PACKING GLAND	WCB / CF8

No	PART	MATERIAL
8	CHUCK	WCB
9	STEM	SS304
10	YOKE	Q235 (Cr.D)
11	YOKE HEAD	Assembly
12	HANDWHEEL	CAST IRON (GGG40)
13	CAP	Q235 (Cr.D)
14	WEDGE	CF8 / CF8M

### Dimension in mm

DN	L	D	D1	D2	D0	N-Th	T	●	⊕	d	H1
50	48	155	120	96	180	4-M16	12	4	0	Ø19	292
65	48	175	140	116	200	4-M16	12	4	0	Ø19	320
80	51	185	150	126	200	8-M16	12	8	0	Ø19	348
100	51	210	175	151	240	8-M16	12	8	0	Ø19	395
125	57	250	210	182	260	8-M20	14	8	0	Ø23	450
150	57	280	240	212	280	8-M20	14	8	0	Ø23	504
200	70	330	290	262	300	12-M20	18	14	0	Ø23	617
250	70	400	355	324	320	12-M22	18	14	0	Ø25	758
300	76	445	400	368	350	16-M22	20	16	0	Ø25	857

The contents of this literature are for informative purposes only. Arita is not responsible for suitability or compatibility of these products in relation to system requirement. For specific requirements, consult Arita or its distributors. Arita reserves the right to change or modify product design without prior notice.